

Axles with independent and electronically controlled suspension

A new integrated system of independent suspension with position control. A revolutionary system (patented by Carraro) which marks a radical development in the four-wheel drive market by ensuring the absorption of stresses induced in the vehicle by the condition of the terrain. The wheels, independently supported by a double wishbone, maintain the vehicle's set up even on rough terrain, while the hydropneumatic suspension provides a damping effect with wide load variation. A range of axles with integrated and independent suspension which is completely interchangeable with the traditional type and does not require any modification to the chassis or transmission shaft.

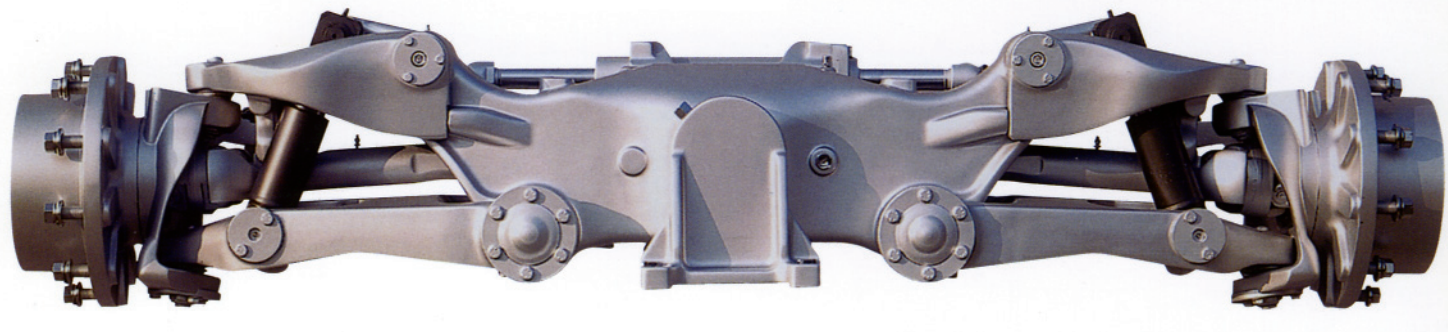

- Range from 70 to 185 HP
- Suspension range +/- 45 mm
- Max pressure of control system 180 bar
- Electronic control integrated in valve unit
- Improved grip (+70% vs. rigid axle at sprung mass frequency)
- Improved damping capacity
- Self-trimming function
- Suspension lock up

Better handling

Precision steering

Higher cross-country speeds

- **Greater productivity**
- **Greater comfort**
- **Greater safety**

Axles with independent and electronically controlled suspension

Model	A Overall width (mm)	B Flange to flange (mm)	δ Max. steering angle	C Hub spigot diameter (mm)	D Wheel studs P.C.D. (mm)	E Wheel studs size	F Susp. wheel travel (mm)	α King - pin angle	β Camber angle	ϕ Caster angle	Peak torque (Nm)	Dynamic load capacity (N)	Static load capacity (N)
20.16SI*	1800	1640	55°	220.8	275	n. 8 studs M18 x 1.5	±45	7°	1°30'	6°	22500	36000	90000
20.19SI	2045	1900	55°	220.8	275	n. 8 studs M20 x 1.5	±45	7°	1°30'	6°	29000	44000	110000
20.22SI	2045	1900	55°	220.8	275	n. 8 studs M20 x 1.5	±45	7°	1°30'	6°	33000	50000	125000
20.25SI	2090	1890	55°	280.8	335	n. 5 studs M22 x 1.5	±45	7°	1°30'	6°	35000	65000	170000
20.29SI	2150	1900	55°	280.8	335	n. 10 studs M22 x 1.5	±45	7°	1°30'	6°	45000	75000	190000
20.43SI	2206	1940	55°	280.8	335	n. 10 studs M22 x 1.5	±45	7°	1°30'	6°	60000	75000	190000

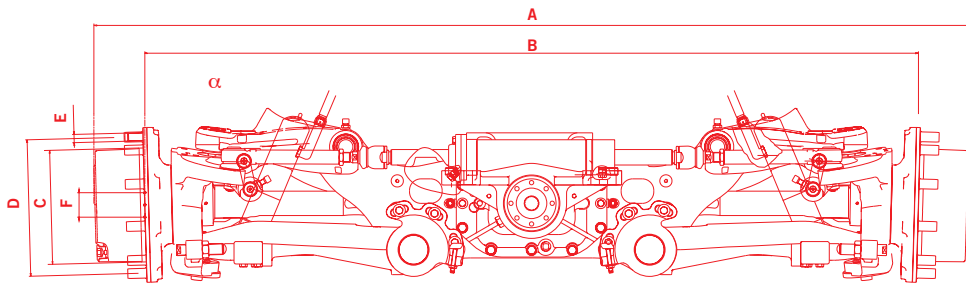

Control unit:
main dimensions

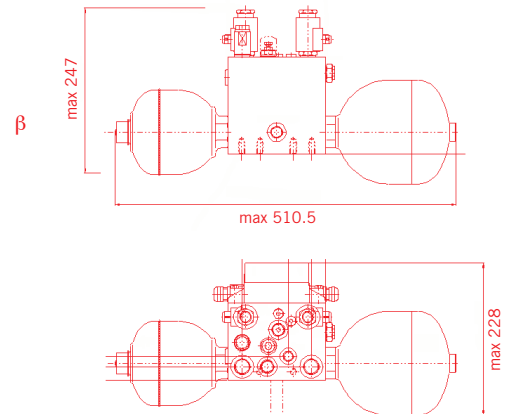

Information are to be considered indicative

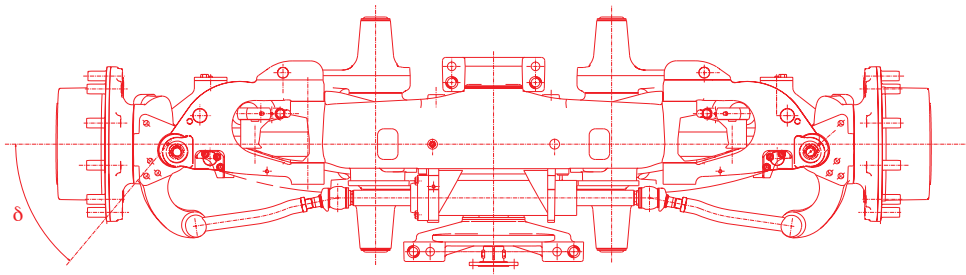

Limited slip differential lock

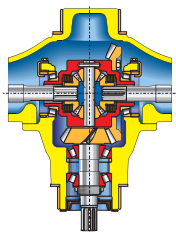

"Ball-type" lim-slip differential lock (Carraro patent)

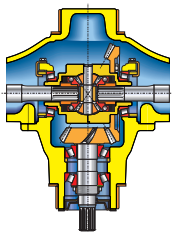

100% mechanical (hydraulic actuation) differential lock

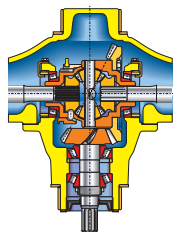

Differential lock with multidisc wet clutch

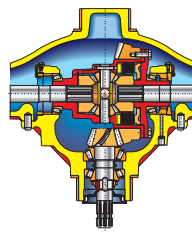

Wet brakes

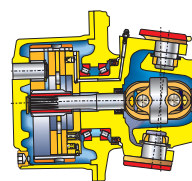

Waterproof seals

