

**MODEL SR2E
REDUCTION GEAR**

Model SR2E is a heavy duty reduction gear having engine rotation that includes a clutch and mounts to an engine for a compact package with proper alignment. The gears are helical and carburized for ultimate strength and endurance. Gears are designed per AGMA specifications. The bearings are tapered roller and the case is heavy cast iron. A wide variety of ratios are available.

CAPACITY (nominal input torque):	600 lb. ft.
MAXIMUM INPUT SPEED:	3000 RPM
RATIOS:	1.42, 1.60, 1.81, 1.97, 2.47, 3.00
BELL HOUSINGS:	SAE #1, #2, #3
CLUTCHES:	SP111, SP211, SP114, SP214
OUTPUT SHAFT:	3.000" diameter, 5.5" long 3/4 x 3/8 keyway
REAR SUPPORT:	4 holes 1/2-13 on rear cover for customer's support plate
LUBRICATION:	Splash
WEIGHT:	800 lbs

07/31/03

MODEL SR2E REDUCTION GEAR

BELLHSG	DIM A
SAE #3	16.63
SAE #2	16.63
SAE #1	18.50

OUTPUT CAN BE ORIENTED
AT 3, 6, 9, OR 12 O'CLOCK POSITION
CONTACT COTTA FOR MOUNTING HOLE LOCATION

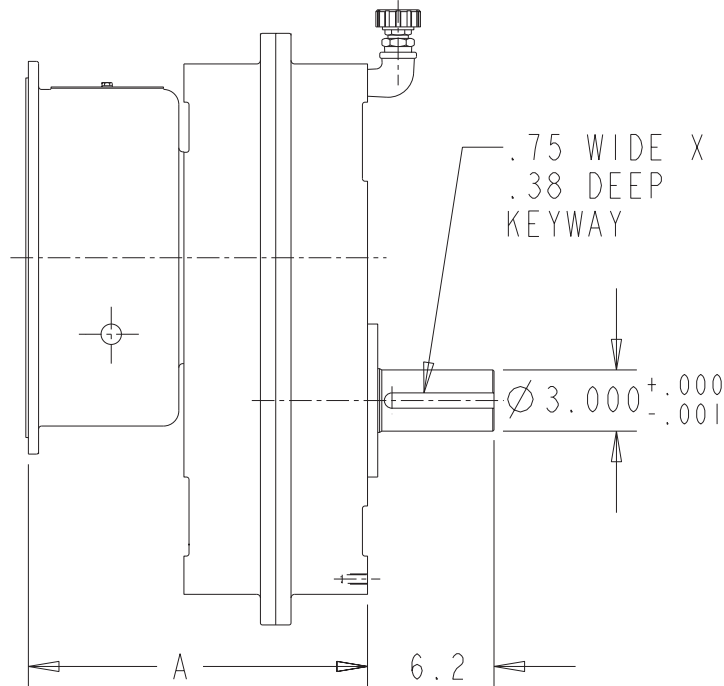

1/2-13 UNC THREAD
TYP (4)
FOR GEARBOX MOUNTING

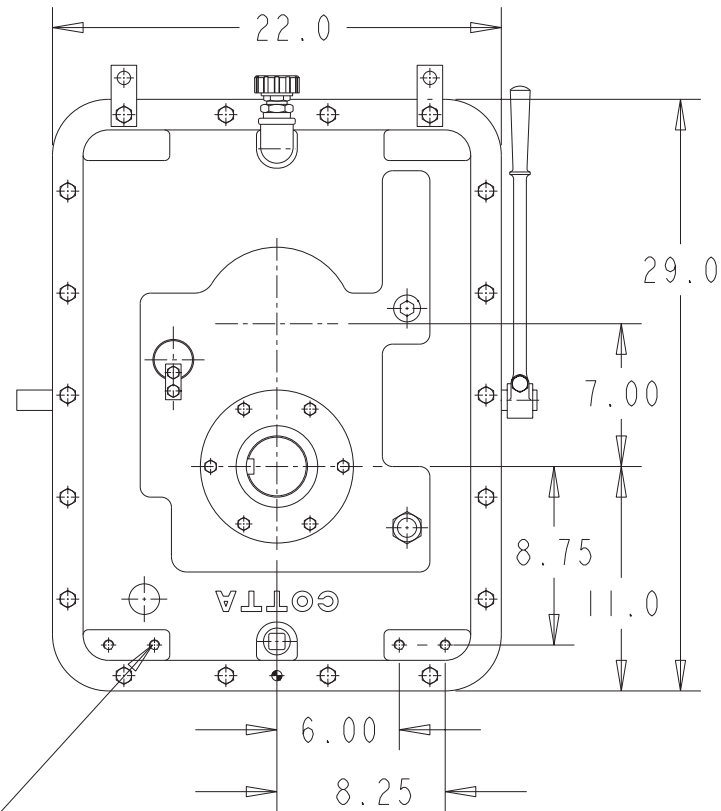

DO NOT USE DIMENSIONS ON THIS DRAWING FOR
INSTALLATIONS, USE CERTIFIED PRINT PROVIDED
WITH ORDERS.