

**MODEL GR3200A  
REDUCTION GEAR**

Model GR3200A is a heavy duty reduction gear having anti-engine rotation that includes a clutch and mounts to an engine for a compact package with proper alignment. The gears are helical and carburized for ultimate strength and endurance. Gears are designed per AGMA specifications and are precision ground. The bearings are taper roller and the case is cast iron. A wide variety of ratios are available.

<b>CAPACITY (nominal input torque):</b>	5500 lb. ft.
<b>MAXIMUM INPUT SPEED:</b>	2200 RPM
<b>RATIOS:</b>	1.19, 1.50, 1.80, 1.92, 2.04, 2.18, 2.50, 2.89
<b>BELL HOUSINGS:</b>	SAE #0, #00
<b>CLUTCHES:</b>	SP318, IBF318, SP321, IBF321 21" rubber block drives and flywheel couplings
<b>OUTPUT SHAFT:</b>	4.750" diameter with 1.25 x .4375 keyway
<b>REAR SUPPORT:</b>	Rear mounting support feet
<b>LUBRICATION:</b>	Lube pump is furnished
<b>COOLING:</b>	A heat exchanger is furnished
<b>WEIGHT:</b>	1800 lbs

Note—For ratios 3.05, 3.29 and 3.56 see Model GR3210A

07/31/03

# MODEL GR3200A REDUCTION GEAR

BELLHSG SAE #	DIM A	DIM B
#0	14.5	24.63
#0 (DEEP)	16.75	26.88
#0 (EXTRA DEEP)	19.0	29.12
#00	14.5	24.62
#00 (DEEP)	19.0	29.12

CONTACT COTTA FOR OTHER  
OUTPUT ORIENTATIONS  
(3, 9, OR 12 O'CLOCK)

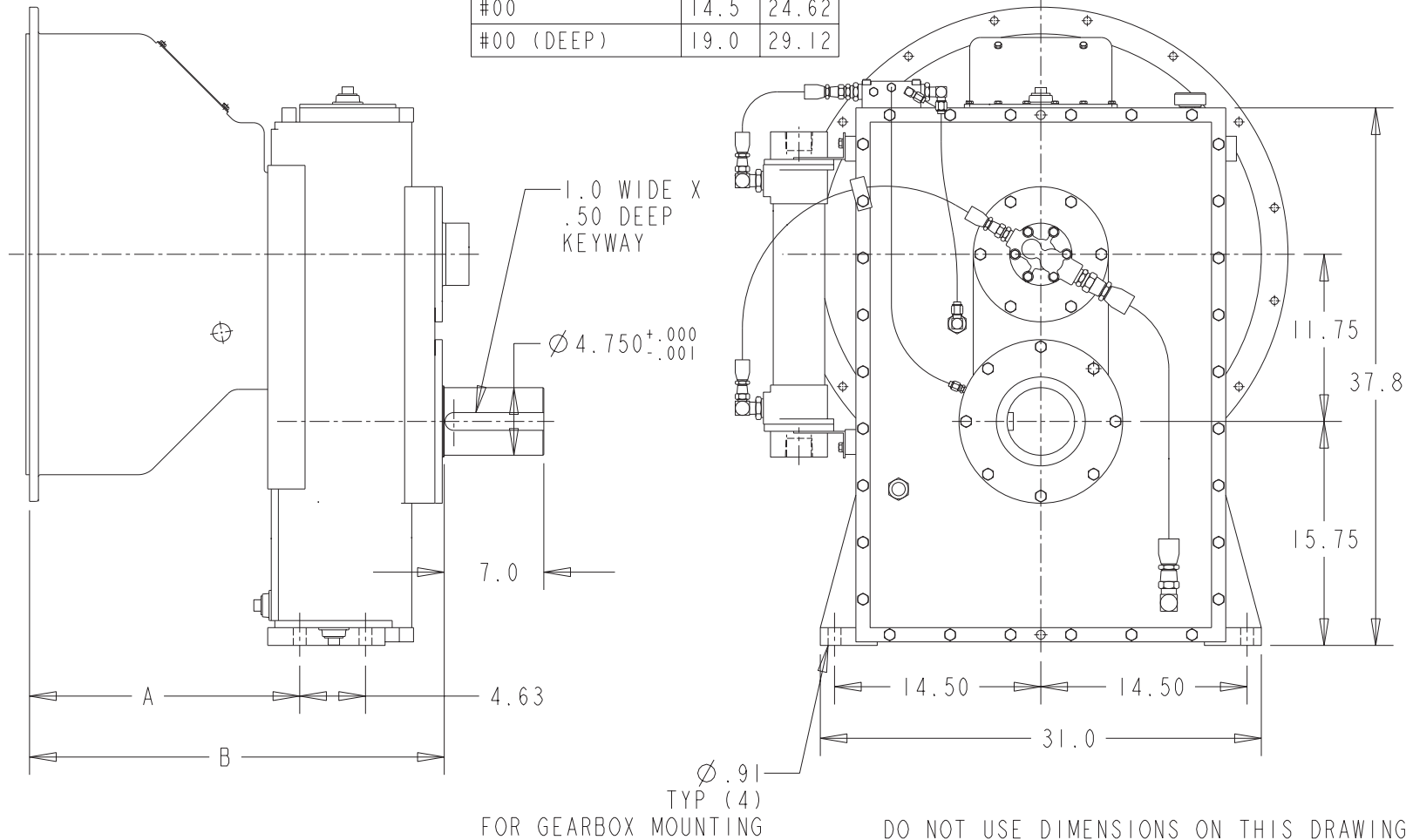

DO NOT USE DIMENSIONS ON THIS DRAWING FOR  
INSTALLATIONS, USE CERTIFIED PRINT PROVIDED  
WITH ORDERS.