

TD61-1180
UP TO 705 HP (526 KW)

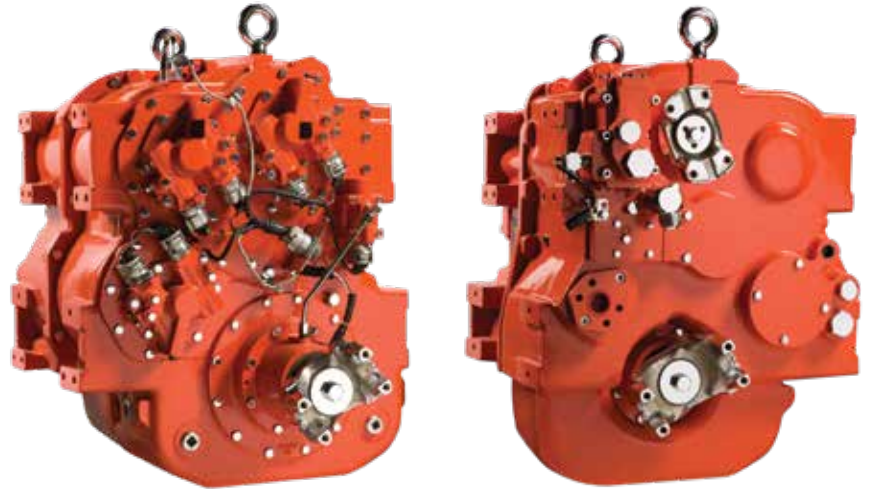

The Twin Disc 1180 series transmission system consists of an engine mounted type 8 torque converter, remote mounted 6 speed automatic transmission and the advanced TDEC-501 electronic control system.

FEATURES & BENEFITS

- Robust automatic transmission system equipped with oversized internal clutch assemblies allows full power shift capability without the need for throttle dipping.
- Only commercially available drive system to offer continuous pump-and-roll functionality at rated engine power levels.
- Our advanced TDEC-501 electronic control systems are specifically tailored for each ARFF application and enable rapid acceleration, faster shifts and precise speed control to handle varying ground conditions, all while seamlessly integrating control of regular drive and pump-and-roll (work) modes.
- Durable ARFF transmission system utilizes the same components used in heavy-duty off-highway vehicles, ensuring long life and reliable performance in ARFF vehicle applications.
- Full time, all-wheel drive, remote mounted, countershaft transmission with options for 30/70, 50/50 and 70/30 biasing differentials for superior performance in off-road conditions.



TDEC-501
ELECTRONIC CONTROL SYSTEM

Range	1st	2nd	3rd	4th	5th	6th	Reverse	Overall
Ratio	6.70	4.39	2.90	1.89	1.24	0.82	7.44	8.17
Step	1.53	1.51	1.53	1.52	1.51	—	—	—

Specifications subject to change without prior notice in the interest of continual product improvement. Contact your local Twin Disc representative for engineering specifications. Patent pending.



TD61-1180 ARFF SPECIFICATIONS

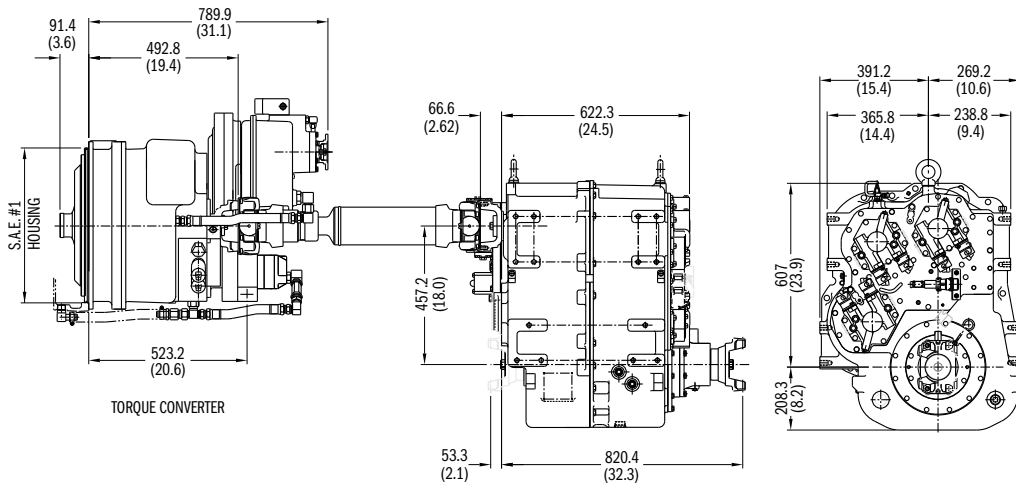

Range	6 forward, 1 reverse
Maximum gross input power	705 hp (526 kW)
Maximum input speed	2300 RPM
Weight, dry (transmission only)	1700 lbs (770 kg)
Maximum oil temperature at converter outlet	250°F (121°C)
Sump capacity	7 USG (26.5 L)
Cooling required	~25% of GHP
Cooling pump capacity	~44 GPM @ 2100 RPM
Mounting	Torque Converter – SAE #1, Transmission – remote trunnion style
Differential	30/70, 50/50, 70/30 with differential lock
Additional	Configurable input and output flanges, PTO options and other accessories. Consult factory.

Important Notice: Torsional Vibration

Disregarding system torsional compatibility could cause damage to components in the drive train resulting in loss of mobility. At minimum, system incompatibility could result in gear clatter at low speeds.

The responsibility for ensuring that the torsional compatibility of the system is satisfactory rests with the assembler of the drive and driven equipment.

Torsional vibration analysis can be made by the engine builder, marine survey societies, independent consultants and others. Twin Disc is prepared to assist in finding solutions to potential torsional problems that relate to the transmission.

Twin Disc, Incorporated reminds users of these products that their safe operation depends on use in compliance with engineering information provided in our catalog. Users are also reminded that safe operation depends on proper installation, operation and routine maintenance and inspection under prevailing conditions. It is the responsibility of users (and not Twin Disc, Incorporated) to provide and install guards or safety devices which may be required by recognized safety standards or by the Occupational Safety and Health Act of 1970 and its subsequent provisions.

Since 1918, we've been putting horsepower to work by designing, engineering and manufacturing rugged-duty industrial products. Our products and our reputation are bolted to the most renowned engine manufacturers and equipment OEMs in the world. Our mission is to make boats, machines and off-highway vehicles more productive, more durable, more operator-friendly, and more cost-effective. From design and installation consultation through after-sale support, Twin Disc and its distributors are committed to your business. No one knows more about managing horsepower in more ways than Twin Disc.

- POWER-SHIFT TRANSMISSIONS
- TORQUE CONVERTERS
- ELECTRONIC CONTROL SYSTEMS
- POWER TAKE-OFFS
- PUMP DRIVES
- CLUTCHES
- GEARBOXES
- UNIVERSAL CONTROL DRIVES



Twin Disc, Incorporated
 Racine, Wisconsin 53403 USA
 Phone +1-262-638-4000
 Fax +1-262-638-4482
 www.twindisc.com